

# PRODUCT DATA SHEET

CLA BLUESUB05 • 811500



BRAND



## PRODUCT DETAILS

The CLA BlueSub05 is a rugged and durable drainage pump designed for use in the construction industry to shift water containing abrasive materials from low lying areas. From the industrial grade coating to the impact resistant Urethane strainer, this pump is designed to withstand the knocks when de-watering construction sites, pits, storm water, basements and other low lying areas.

## BENEFITS

- The urethane coated impeller is fitted with an agitator to break up clumps of abrasive material
- With a knock resistant urethane strainer BlueSubwill withstand the realities of everyday use.

## FEATURES

- Automatic Operation via flexible float
- Quality pump materials and construction to resist abrasive particles
- Industrial grade coating
- 10m H07RN-F Neoprene power lead and float cable

Also available:

BIA-LAYFLATKIT 707755

2" lay-flat hose and camlock connector, 20m long

## TECHNICAL DATA

P2 RATED POWER (W)	500W
MAX. FLOW [LPM]	210 lpm
MAX. HEAD [M]	12m
WORKING TEMPERATURE	< 40°C
LIQUID TEMPERATURE	2°C - 35°C
MAX. IMMERSION DEPTH	7m
MAX. DIA. OF PARTICLE	10 x 25mm
MOTOR DUTY	S1 Continuous
MOTOR PROTECTION LEVEL	Class F
MOTOR PROTECTION	In-built auto re-setting thermal overload
CAPACITOR	15 uF +/-5% 450V
MOTOR SHAFT	Stainless Steel 403

RATED VOLTAGE	220V-240V 50 Hz
RATED CURRENT	2.8A @ 230V
POWER CABLE TYPE	10m H07RN-F
PROTECTION CLASS	IP68
IMPELLERS	Single Urethane Coated Impeller
HYDRAULIC BODY	Cast Iron
INLET STRAINER	Urethane
OUTLET	45 deg elbow and 2" camlock
MECHANICAL SEALS	Dual seals in oil bath
AUTOMATION FUNCTION	Yes via Flexible Float Switch
NET WEIGHT (KG)	Pump only 13.0 kg
PACKAGE DIMENSION	260Lx205Wx410H (mm)

## HYDRAULIC PERFORMANCE

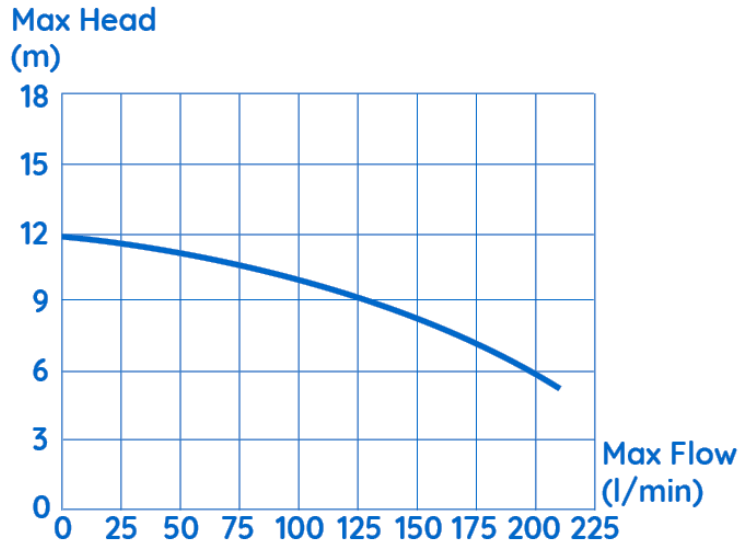

## DIMENSIONS

### DIMENSIONS

356 mm high

### OUTLET

2" DN Hose Tail

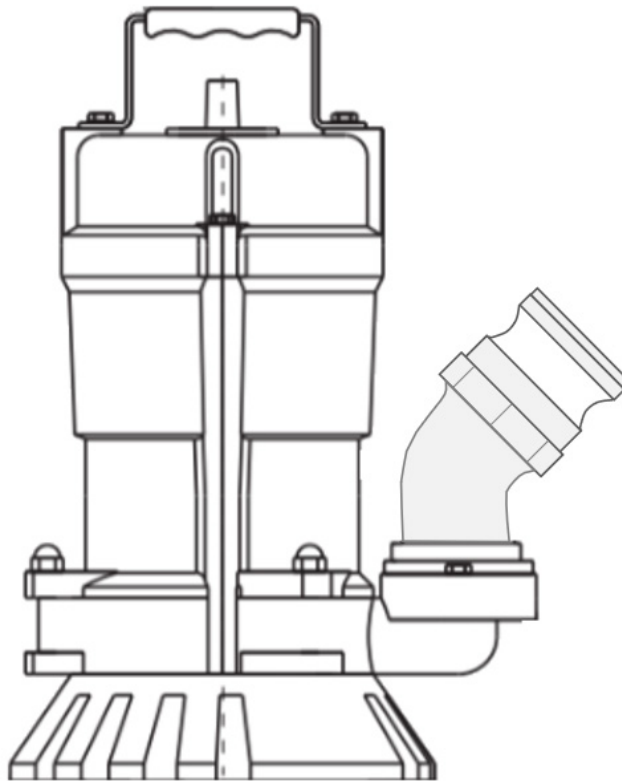

### BASE DIAMETER

Dia 185 mm, 239 total width

## WARRANTY / CERTIFICATIONS

